



Zebra[®] Smart Charger 2 (SC2)
for Mobile Printers

User Guide



P1040985-001 Rev. D
March, 2012

Table of Contents

Proprietary Statements.....	3
Liability Disclaimer.....	3
No Liability for Consequential Damage.....	3
Copyrights.....	4
Document Conventions.....	5
Charger Safety.....	6
Installation.....	6
Indicator and Parts Descriptions.....	7
Descriptions.....	7
Charger Operation.....	8
The SC2 Smart Charger.....	8
Charging Status Indicators.....	8
Battery Health Indicators.....	9
Preventive Maintenance.....	10
Extending Battery Life.....	10
Appendix A: Technical Specifications.....	11

Proprietary Statements

This manual contains proprietary information of Zebra Technologies Corporation. It is intended solely for the information and use of parties operating and maintaining the equipment described herein. Such proprietary information may not be used, reproduced, or disclosed to any other parties for any other purpose without the expressed written permission of Zebra Technologies Corporation.

Product Improvements

Since continuous product improvement is a policy of Zebra Technologies Corporation, all specifications and signs are subject to change without notice.

Agency Approvals and Regulatory Information

- FCC part 15 Class B
- Canadian STD ICES-003 Class B
- EN55022 Class B
- EN55024 European Immunity Standard
- GB4943 Safety
- GB9254
- GB17625.1
- UL 60950
- IEC60950
- NOM(Mexico)
- SAA (Australia/New Zealand)
- C-Tick (Australia/New Zealand)
- CE (EU/EFTA)
- PSE (Japan)
- SABS (South Africa)
- S mark (Argentina)
- GOST-R (Russia)
- KC (Korea)
- SII (Israel)
- Ukrsepro (Ukraine)
- ST (Malaysia)

Liability Disclaimer

Inasmuch as every effort has been made to supply accurate information in this manual, Zebra Technologies Corporation is not liable for any erroneous information or omissions. Zebra Technologies Corporation reserves the right to correct any such errors and disclaims liability resulting therefrom.

No Liability for Consequential Damage

In no event shall Zebra Technologies Corporation or anyone else involved in the creation, production, or delivery of the accompanying product (including hardware and software) be liable for any damages whatsoever (including, without limitation, damages for loss of business profits, business interruption, loss of business information, or other pecuniary loss) arising out of the use of or the results of use of or inability to use such product, even if Zebra Technologies Corporation has been advised of the possibility of such damages. Because some states do not allow the exclusion of liability for consequential or incidental damages, the above limitation may not apply to you.

Copyrights

The copyrights in this manual and the label print engine described therein are owned by Zebra Technologies Corporation. Unauthorized reproduction of this manual or the software in the label print engine may result in imprisonment of up to one year and fines of up to \$10,000 (17 U.S.C.506). Copyright violators may be subject to civil liability.

This product may contain ZPL, ZPL II, and ZebraLink™ programs; Element Energy Equalizer Circuit; E3; and AGFA fonts. Software . ZIH Corp. All rights reserved worldwide.

ZebraLink and all product names and numbers are trademarks, and Zebra, the Zebra logo, ZPL, ZPL II, Element Energy Equalizer Circuit, and E3 Circuit are registered trademarks of ZIH Corp. All rights reserved worldwide.

Monotype , Intellifont and UFST are trademarks of Monotype Imaging, Inc. registered in the United States Patent and Trademark Office and may be registered in certain jurisdictions.

Andy™ , CG Palacio™, CG Century Schoolbook™, CG Triumvirate™, CG Times™, Monotype Kai™, Monotype Mincho™ and Monotype Sung™ are trademarks of Monotype Imaging, Inc. and may be registered in some jurisdictions.

HY Gothic Hangul™ is a trademark of Hanyang Systems, Inc.

Angsana™ is a trademark of Unity Progress Company (UPC) Limited.

Andale, Arial, Book Antiqua, Corsiva, Gill Sans, Sorts and Times New Roman are trademarks of The Monotype Corporation registered in the United States Patent and Trademark Office and may be registered in certain jurisdictions.

Century Gothic™, Bookman Old Style™ and Century Schoolbook™ are trademarks of The Monotype Corporation and may be registered in certain jurisdictions.

HGPGothicB is a trademark of the Ricoh company, Ltd. and may be registered in some jurisdictions.

Univers™ is a trademark of Heidelberger Druckmaschinen AG, which may be registered in certain jurisdictions, exclusively licensed through Linotype Library GmbH, a wholly owned subsidiary of Heidelberger Druckmaschinen AG.

Futura is a trademark of Bauer Types SA registered in the United States Patent and Trademark Office and may be registered in some jurisdictions.

TrueType is a trademark of Apple Computer, Inc. registered in the United States Patent and Trademark Office and may be registered in certain jurisdictions.

All other brand names, product names, or trademarks belong to their respective holders.

Document Conventions

The following conventions are used throughout this document to convey certain information:



Caution • Warns you of the potential for electrostatic discharge.



Caution • Warns you of a potential electric shock situation.



Caution • Warns you of a situation where excessive heat could cause a burn



Caution • Advises you that failure to take or avoid a specific action could result in physical harm to you.



Caution • Advises you that failure to take or avoid a specific action could result in physical harm to the hardware.



Important • Advises you of information that is essential to complete a task.



Note • Indicates neutral or positive information that emphasizes or supplements important points of the main text.

Charger Safety

The following notices emphasize certain information specific to the Smart Charger 2.



Do not place a charger in locations where liquids or metallic objects may be dropped on the charger or into the charging bays.



Use care in locating the SC2. Do not block the ventilating slots on the bottom covers. Ensure that the charger is plugged into a power source which won't accidentally be turned off if you will be charging batteries overnight.

Installation

The SC2 is intended to rest on a flat surface such as a table or shelf. It may be attached using the mounting holes shown in the diagram below.

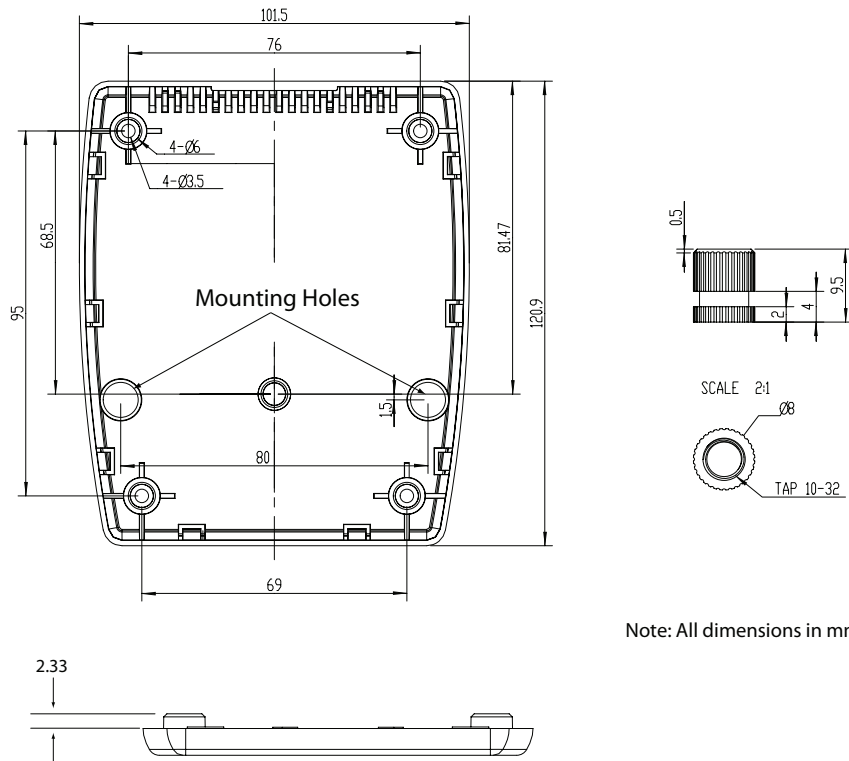

Note: All dimensions in mm

Indicator and Parts Descriptions

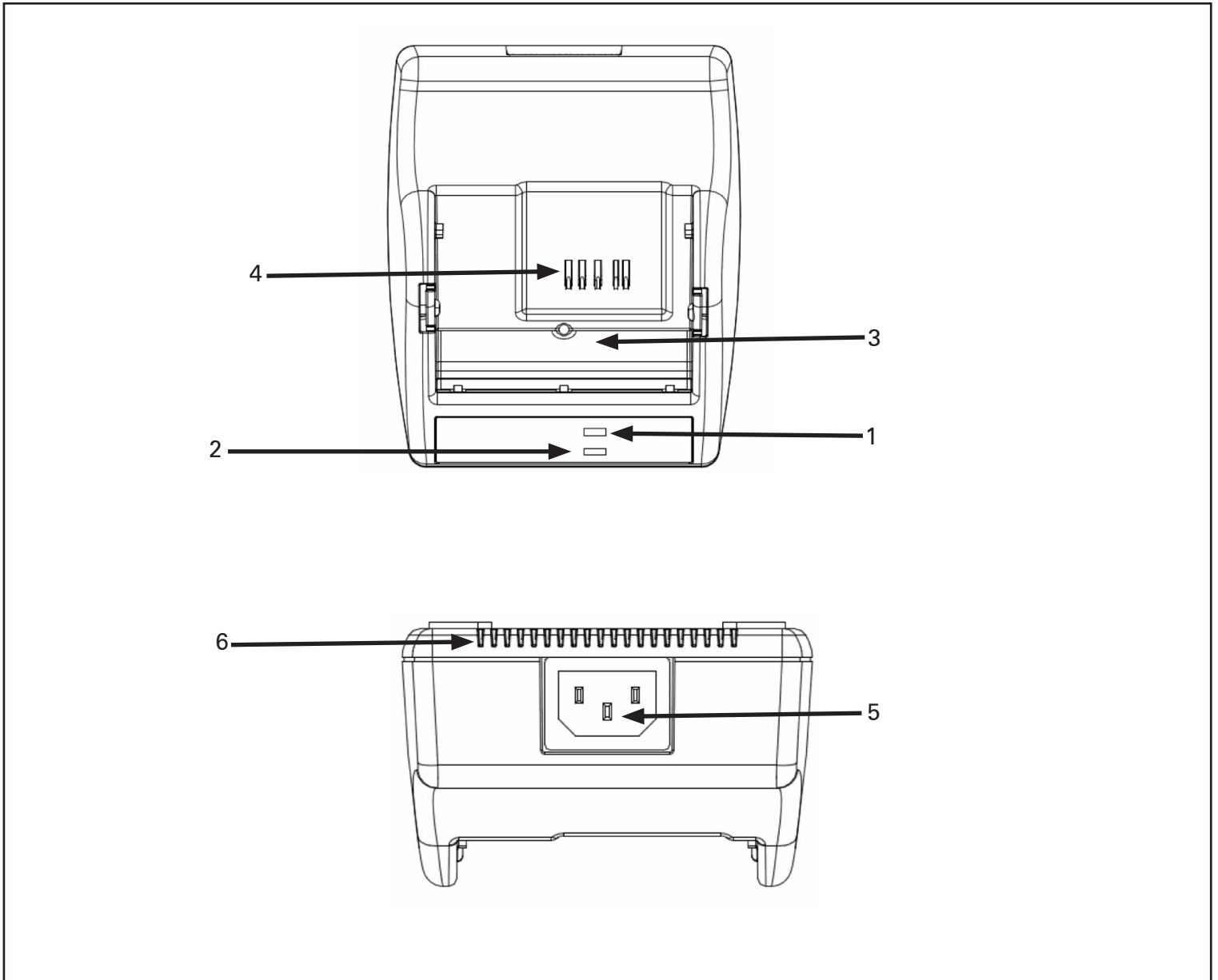

Descriptions

1. Battery Charging Indicator
2. Battery Health Indicator
3. Charging Bay
4. Battery Contact
5. AC Jack
6. Ventilating Slots

Charger Operation

The following table lists the batteries approved for use with the Smart Charger 2.



Use of chargers not approved by Zebra specifically for use with the Zebra series of printers will void the warranty and could cause damage to the printer or the battery pack. Zebra is not responsible for any damage to equipment caused by the improper use of unauthorized equipment.

Description of Batteries Supported	Part Number
Smart Battery for QLn220/320	P1031365-025
Smart Battery for P4T, RW4-PS	AK18913-001
Battery for QL 220/QL 320/QL 220 Plus/QL 320 Plus	AT16004-1
Battery for QL 420/QL 420 Plus	AT16293-1
Battery for RW 220	AK18026-002
Battery for RW 420	AK17463-005



Consult your Zebra sales representative or the factory for the appropriate full part number.

The SC2 Smart Charger

The Smart Charger 2 is an AC fast charger with a universal 100 to 240, 50-60 Hz. VAC input. This charger is intended for charging the Lithium Ion (Li-ion) batteries pack that to be used in the Zebra mobile printers.

The Smart charger will charge a battery pack as fast as its charge level will allow, and then switch over to a maintenance charge to keep the charge at its maximum.

Charging Status Indicators

Plug the SC2 into the AC wall receptacle using the supplied power cable, and then insert the battery into the charging bay. The Battery Charging Indicator LED will report the charge status as per the following table.

DC Power Input	Indicator	Battery Status
Present	Green	Battery Not Present
Present	Green	Battery Present & Fully Charged
Present	Yellow	Charging
Present	Amber	Fault
Present	Off	Present and Battery Health = POOR

Battery Health Indicators

The SC2 features a tri-color (Yellow/Green/Amber) LED to indicate the health of the battery pack. An evaluation of the battery health begins upon insertion of the battery in the charger and results in the appropriate LED being illuminated as shown below.

Battery	Indicator	Health Status
None or non-smart	Off	BATTERY/POWER NOT PRESENT
Smart battery present	Green	GOOD
Smart battery present	Yellow	REPLACE
Smart battery present	Flashing yellow	REPLACE (NEAR END OF USEFUL LIFE)
Smart battery present	Amber	POOR (NO LONGER USABLE)



Ensure that the charger has been installed properly per the charger instruction manual.



Ensure that the SC2 is plugged into the appropriate AC wall receptacle.



Remove any protective shrink-wrap and labels from all battery packs prior to first use.



Snap the battery pack into the charging bay until it stops.



The battery health indicator will be Amber if the battery is improperly inserted.



The battery must be fully charged before being installed in the printer.

Preventive Maintenance

Extending Battery Life

- Avoid exposing the battery to direct sunlight or temperatures over 104 °F (40 °C).
- Always use a Zebra charger designed specifically for Lithium-Ion batteries. Use of any other kind of charger may damage the battery.
- Use the correct media for your printing requirements. An authorized Zebra re-seller can help you determine the optimal media for your application.
- If you print the same text or graphic on every label, consider using a preprinted label.
- Choose the correct print darkness and print speed for your media.
- Use the LCD display backlight only when necessary. Turn it off whenever it is not needed.
- Remove the battery from the printer if it won't be used for a day or more and you're not performing a maintenance charge.
- Consider purchasing an extra battery.
- Remember that any rechargeable battery will lose its ability to maintain a charge over time and can be recharged only a finite number of times before it must be replaced.



Always dispose of used batteries properly.

Appendix A: Technical Specifications

Physical

- Height: 2.5 in (63.4 mm)
- Length: 4.8 in (121 mm)
- Width: 4.0 in (101.5 mm)
- Weight (charger only): 0.55 lbs (0.25 kg)
- Weight (cradle and line cord): 0.90 lbs (0.41 kg)

Environmental

- Operating Temp: 32°F (0°C) to 104°F (40°C)
- Storage Temp: -13°F (-25°C) to 158°F (65°C)
- Humidity: 10% to 90% non-condensing
- Drop: 3 ft (0.9M) to concrete (with battery)
- Vibration: Per Mil-Std-810

Power:

- AC Input: 100 – 240 VAC, 50 – 60 Hz, 0.8A
- DC Output: 8.4 VDC, 1.5A max
- 2011 Energy Star Compliant



Zebra Technologies Corporation

475 Half Day Road, Suite 500

Lincolnshire, IL 60069 USA

T: +1 847.634.6700 or +1 800.423.0442